

Product title:

MOTOR SPRING M16LE61721

Product image:

Product price:

€169.40

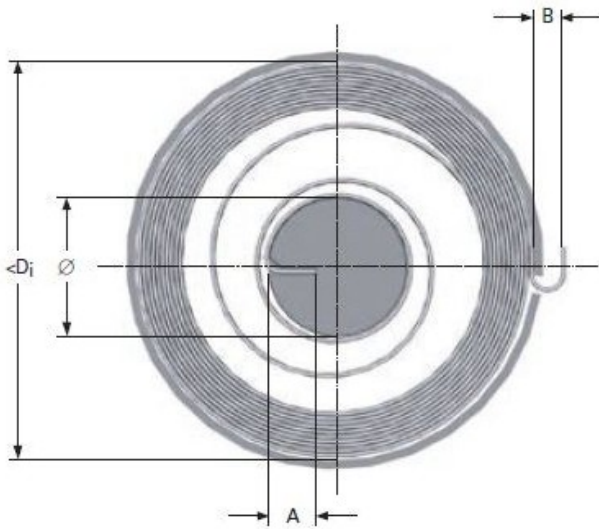

Product short description:

MOTOR SPRING M16LE61721

Product features:

INSIDE DIAMETER: 77
TOTAL COILS: 20
RAW MATERIAL THICKNESS: 0.28
BAND WIDTH: 10
SHAFT DIAMETER: 12
LEG LENGTH: 3
TORQUE: 90
MAXIMUM TORQUE: 290
TAIL WIDTH: 4