

Product title:

MOTOR SPRING M16LE8990

Product image:

Product price:

€183.54

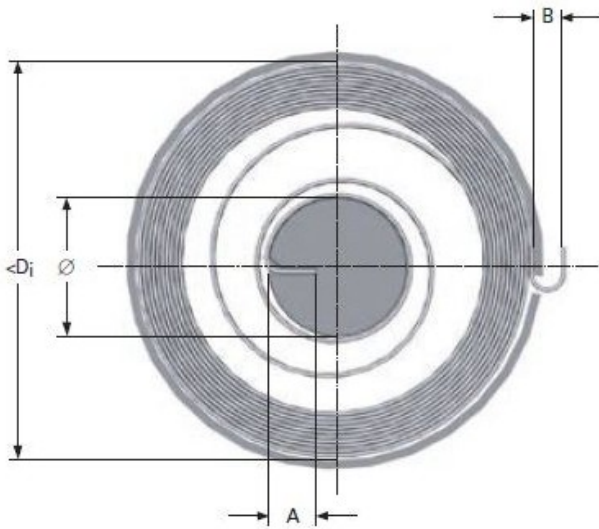

Product short description:

MOTOR SPRING M16LE8990

Product features:

INSIDE DIAMETER: 116
TOTAL COILS: 20
RAW MATERIAL THICKNESS: 0.6
BAND WIDTH: 12
SHAFT DIAMETER: 18
LEG LENGTH: 5
TORQUE: 153
MAXIMUM TORQUE: 709
TAIL WIDTH: 5