

Product title:

# MOTOR SPRING M16LE61711

Product image:

Product price:

**€203.28**

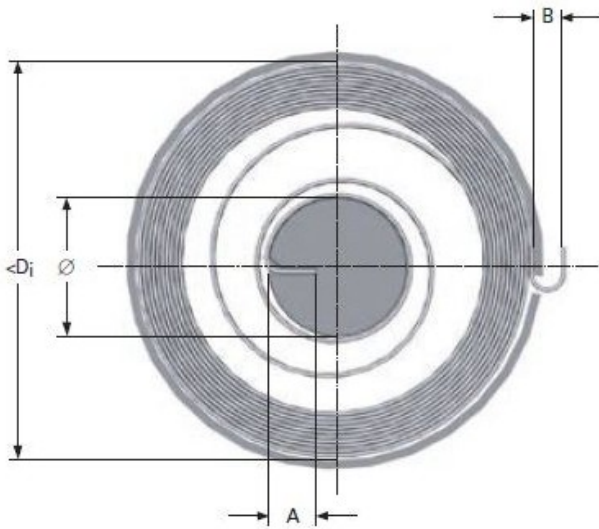

Product short description:

MOTOR SPRING M16LE61711

Product features:

INSIDE DIAMETER: 115  
TOTAL COILS: 10  
RAW MATERIAL THICKNESS: 0.56  
BAND WIDTH: 12  
SHAFT DIAMETER: 25  
LEG LENGTH: 7  
TORQUE: 480  
MAXIMUM TORQUE: 1250  
TAIL WIDTH: 6