

Product title:

MOTOR SPRING M16LE61709

Product image:

Product price:

€183.92

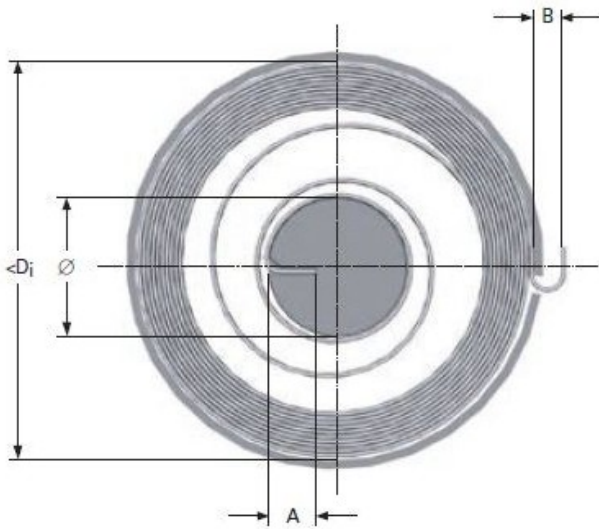

Product short description:

MOTOR SPRING M16LE61709

Product features:

INSIDE DIAMETER: 100
TOTAL COILS: 10
RAW MATERIAL THICKNESS: 0.47
BAND WIDTH: 15
SHAFT DIAMETER: 20
LEG LENGTH: 6
TORQUE: 450
MAXIMUM TORQUE: 1180
TAIL WIDTH: 6