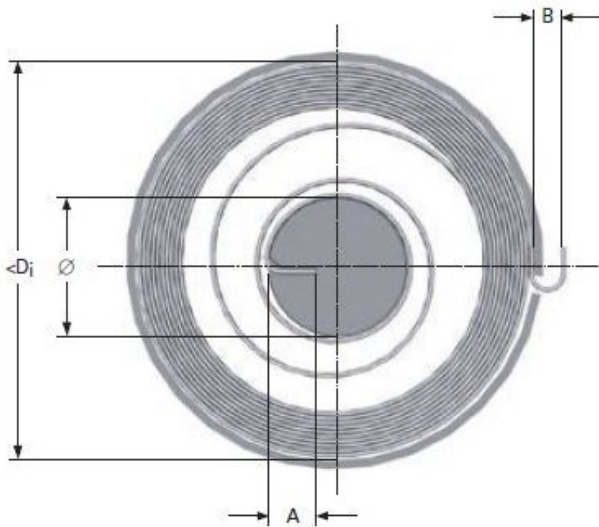

Product title:

MOTOR SPRING M16LE8978

Product image:

Product price:

€252.02

Product short description:

MOTOR SPRING M16LE8978

Product features:

INSIDE DIAMETER: 145
TOTAL COILS: 10
RAW MATERIAL THICKNESS: 1
BAND WIDTH: 15
SHAFT DIAMETER: 30
LEG LENGTH: 8
TORQUE: 570
MAXIMUM TORQUE: 2312
TAIL WIDTH: 8