

Product title:

## Double torsion spring according to DIN 2089

Product image:

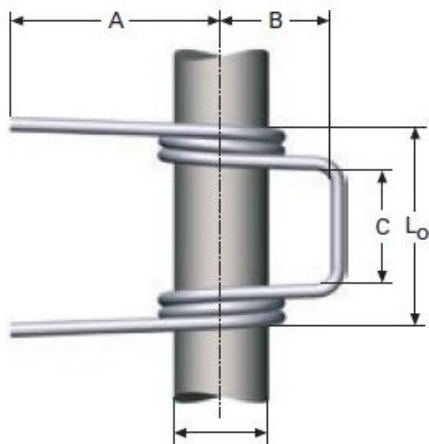

Product price:

**€26.76**

Product short description:

Muelle de doble torsion LEDT8565

Product features:

Location:

FREE ANGLE POSITION: A

SKU: LEDT8565

LENGTH LEGS: 40

SHAFT DIAMETER: 8

FRAME LENGTH: 12

FRAME WIDTH: 11

LENGTH BETWEEN LEGS: 18.5

INSIDE DIAMETER: 9

WIRE DIAMETER: 1.25

RAW MATERIAL: EN 10270-3 1.4310

COILS ON EACH BODY: 2

MAXIMUM PERMITTED TORQUE: 476

TORQUE ANGLE AT MN (?): 38

Product description:

- Double torsion spring according to DIN 2089
- Brand name: LESJÖFORS Springs
- Raw material: Stainless steel;EN 10270-3-1.4310
- Cycles guarantee : Infinite if working without reaching yield point
- All measures are in N. and mm.

{tab Delivering time}

{article 8 days delivering time} {text} {/article}

{tab Technical information}

Coming soon

Coming soon

{/tabs}